

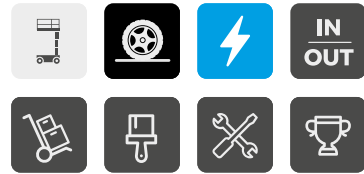

STAR 13



GO EVERYWHERE

- > Smooth & precise driving
- > Comfort & agility
- > Indoor / outdoor rated (versatile)
- > Easy entry to the platform
- > Smart transportability and lifting

THE BEST VALUE FOR THE MONEY

- > Haulotte Activ'Energy Management takes care of your batteries
- > Easy access to components
- > Smart mast system
- > Minimal maintenance & downtime
- > Direct electric drive brushless AC motor
- > Haulotte Activ'Screen (onboard diagnostics)

**AERIAL
TITANS**

866-874-0584
WWW.AERIALTITANS.COM

STANDARD EQUIPMENT

VERTICAL MASTS

TECHNICAL DATA

STAR 13

Working height	18 ft 6 in
Platform height	12 ft 6 in
Horizontal outreach	N/A
Lift capacity	507 lb (2 pers.)
Lift capacity - outside	507 lb (1 pers.)
A Length	4 ft 7 in
B Width	2 ft 7 in
C Height - stowed	5 ft 9 in
D Wheelbase	3 ft 6 in
E Ground clearance	2.36 in
Platform size	2 ft 6 in x 4 ft 6 in
Platform size with extension (option)	2 ft 6 in x 4 ft 6 in + 16 in
Drive speed	0.5 - 2.8 mph
Turning radius - outside	5 ft 7 in
Tilt alarm	1.5 ° / 3 °
Gradeability	25 %
Driveable at full height up to	12 ft 6 in
Tires	13 x 5
Batteries	12 V - 105 Ah (C5)
Weight	1,962 lb

- > Haulotte Activ'Energy Management: Smart CAN charger
- > 24 V electric drive brushless AC motors
- > 2 x 12 V - 105 Ah batteries
- > Battery charge indicator
- > Haulotte Activ'Screen
- > Forklift pockets
- > Hoisting and lifting eyes
- > Saloon door entry gate
- > Mobile pothole protection
- > 2 Front steering wheels
- > 2 Rear drive wheels
- > Non-marking tires
- > Brake release
- > Hourmeter
- > Horn
- > Travel alarm
- > Emergency stop
- > Emergency hand pump
- > 2 control stations at platform and ground level
- > Mobile upper control box
- > 2 towing hooks
- > Walkable entry plinth

OPTIONS AND ACCESSORIES

- > Haulotte Activ'Energy Management: automatic or manual battery waterfilling systems
- > Upper control box cover
- > Tool tray
- > 16 in platform extension deck (stowed height 5 ft 9.5 in) standard in US & Canada
- > Power to the platform
- > Ground-fault circuit interrupter 30 mA
- > Telematics ready
- > Biodegradable hydraulic oil
- > Cold weather hydraulic oil
- > Flashing beacon
- > Fluorescent tube caddy

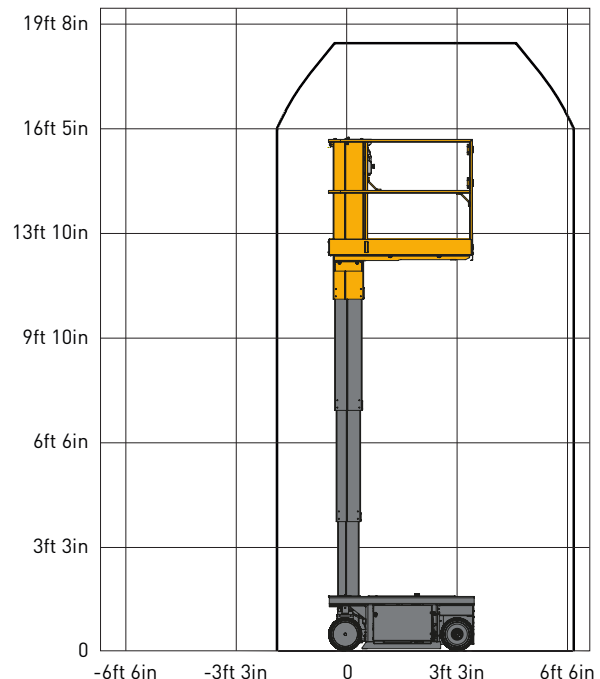
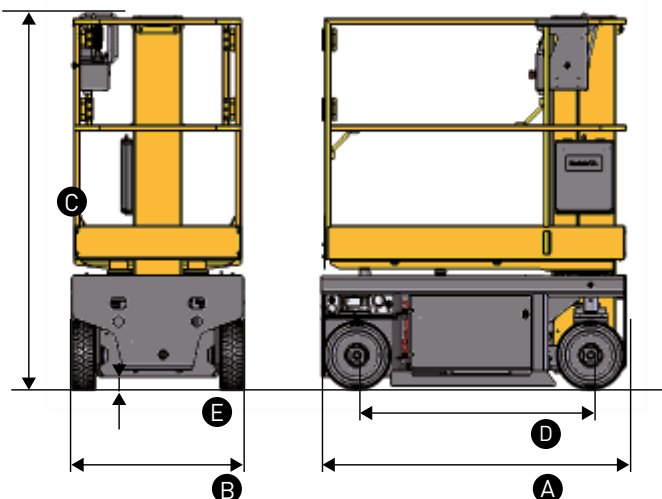

4000820350 - Non-contractual document - We reserve the right to change the technical characteristics of this document without notice - 06/2021