



SJ82/86 T TELESCOPIC BOOMS

STANDARD FEATURES

- EASYDRIVE™ Direction sensing drive and steer controls
- AXLDRIIVE™ Axle-based 4WD system
- Operator controlled locking rear differential and limited slip front differential
- Oscillating steer axle
- Drivable at full height
- 45% Gradeability
- Wet disc SAHR brakes (front and rear axle)
- Relay based control system with SKYCODED™ color coded and numbered wiring
- Deutz TD2.9L4 diesel engine
- Swing out engine tray
- Swing up cowlings for easy access
- Lockable power disconnect switch
- Proportional controls
- 500/750 lbs (227/341 kg) Dual capacity
- 36" x 96" Platform
- Bolt-in platform railing system
- Lanyard attachment points
- Tri-entry sliding mid rails
- Secondary Guarding Electrical (SGE)
- Overload sensing system
- 110V AC Outlet on platform with GFI
- Tilt alarm (5.0° x 5.0°) with drive and lift cut-out
- Single point emergency lowering
- Hourmeter
- Operator horn
- All motion alarm
- 360° Continuous turret rotation
- Tie down/lifting lugs
- 18 x 625 Grip lug foam-filled tires
- Telematics ready
- 2-Year Gold Leaf Warranty (5-year structural warranty)

OPTIONS

- Glazier kit
- Pipe rack
- Tool caddy
- Flashing light
- 36" x 72" Platform
- Side spring hinged entry gate
- Auxiliary top rail (36" x 96" platform only)
- 3.5 kW Generator (Includes hydraulic oil cooler)
- Welder ready package (Includes 12 kW generator, hydraulic oil cooler, 3-phase power connection in platform, and welder mount)
- Welder package (Includes 12 kW generator, hydraulic oil cooler, 3-phase power connection in platform, welder mount, and Lincoln V275-S welder)
- Cold weather start kit (Recommended for regions where average monthly low temperatures can reach 14°F / -10°C (Includes cold start engine oil, battery blanket, hydraulic tank heater, and engine load kit (Deutz TD2.9L4))
- Arctic weather package (Recommended for regions where average monthly low temperatures can reach -0.4°F / -18°C (Includes arctic engine oil, battery blanket, hydraulic tank heater, engine load kit (Deutz TD2.9L4), block heater, arctic hydraulic oil, arctic platform rotator and arctic gear oil in the axles and swing drive glow plugs, arctic hydraulic hoses (all), and oversized foot switch cover are also included (standard equipment).)
- Positive air shut-off valve (diesel only)
- Hydraulic oil cooler
- Bio oil
- Hostile environment package (Includes cylinder bellows, boom wipers, covers for the fly boom cutouts, and control box cover)
- Control box cover
- Lifting Lugs
- 18 x 625 Grip lug foam-filled non-marking tires
- Non-destructive testing
- ELEVATE telematics

† Standard lead times may be increased when optional equipment is added, consult factory.
‡ Capacities and machine weights may differ when options are added.

SJ82/86 T TELESCOPIC BOOMS

| Dimensions | SJ82 T | SJ86 T |
|-------------------------------------|------------------------------|------------------------------|
| Work Height | 88' (26.82 m) | 92' (28.04 m) |
| Platform Height | 82' (24.99 m) | 86' (26.21 m) |
| Horizontal Reach | 72' 6" (22.10 m) | 76' 10" (23.42 m) |
| A Platform Size | 36" x 96" (0.91 x 2.44 m) | 36" x 96" (0.91 x 2.44 m) |
| B Stowed Width | 8' 2" (2.49 m) | 8' 2" (2.49 m) |
| C Tailswing | 4' 8" (1.42 m) | 4' 8" (1.42 m) |
| D Stowed Height | 9' 10" (3.00 m) | 9' 10" (3.00 m) |
| E Transportation Height | - | 10' 3" (3.13 m) |
| F Stowed Length | 37' 10" (11.53 m) | 42' 6" (12.95 m) |
| G Transportation Length | - | 34' 9" (10.59 m) |
| H Wheelbase | 11' (3.35 m) | 11' (3.35 m) |
| I Ground Clearance | 16" (0.41 m) | 16" (0.41 m) |
| Specifications | SJ82 T | SJ86 T |
| Rotation | 360° Continuous | |
| Platform Rotation | 170° | 170° |
| Jib Length | - | 5' 6" (1.68 m) |
| Jib Range +/- | - | +65° / -60° |
| Weight | 37,600 lbs (17,055 kg) | 38,691 lbs (17,550 kg) |
| Gradeability | 45% | 45% |
| Turning Radius (Inside) | 11' 6" (3.51 m) | 11' 6" (3.51 m) |
| Turning Radius (Outside) | 21' (6.40 m) | 21' (6.40 m) |
| Axle Oscillation | 4" (10.16 cm) | 4" (10.16 cm) |
| Drive Speed (High speed) | 3 mph (4.8 km/h) | 3 mph (4.8 km/h) |
| Capacity | 500 / 750 lbs (227 / 340 kg) | 500 / 750 lbs (227 / 340 kg) |
| Maximum wind rating | 28 mph (12.5 m/s) | 28 mph (12.5 m/s) |
| Personnel Rating at Max Wind Rating | 2 / 3 | 2 / 3 |
| Tire Type | Foam-Filled | Foam-Filled |
| Tire Size | 18-625 | 18-625 |
| Diesel Engine | Deutz TD2.9L - 74 HP (55 KW) | |
| Fuel Tank Capacity | 45 gal. (170 L) | |
| Hydraulic Reservoir | 60 gal. (227 L) | |

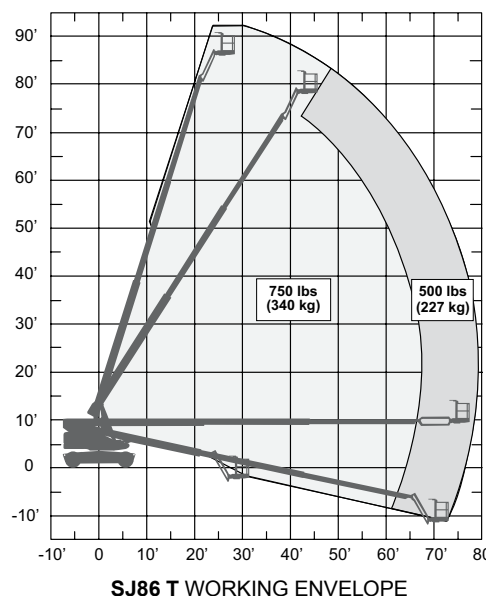
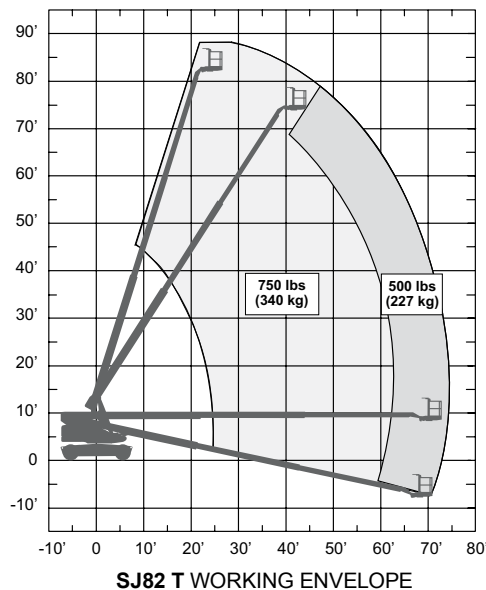
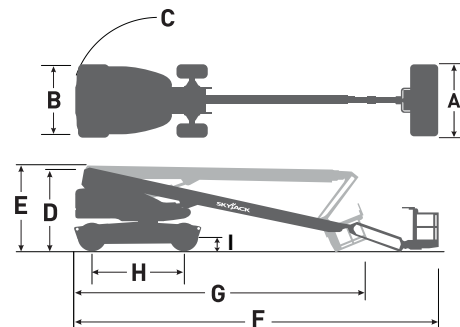

Skyjack Head Office
 55 Campbell Rd. Guelph, ON Canada N1H 1B9
 Sales Inquiries: 1-877-755-4387 (1-877-SJLIFTS)
 Main Switchboard: 1-800-265-2738
 Phone: 519-837-0888
 Fax: 519-837-8104
 Email: skyjack@skyjack.com

www.skyjack.com

AERIAL TITANS
 866-874-0584
 WWW.AERIALTITANS.COM

SKYJACK
 simply reliable