



SJ40/45 T+

TELESCOPIC BOOMS

STANDARD FEATURES

- EASYDRIVE™ Direction sensing drive and steer controls
- AXLDRIVE™ Axle-based 4WD system
- Operator controlled locking rear differential and limited slip front differential
- Oscillating steer axle
- Drivable at full height
- 40% Gradeability
- Wet disc SAHR brakes (rear axle)
- Dual module control system with SKYCODED™ color coded and numbered wiring
- Kubota D1305 Tier 4F diesel engine
- Swing up cowlings for easy access
- Lockable power disconnect switch
- Proportional controls
- Up to 750 / 1,000 lbs Dual capacity
- 36" x 96" Platform
- Bolt-in platform railing system
- Lanyard attachment points
- Tri-entry sliding mid rails
- Secondary Guarding Electrical (SGE)
- Overload sensing system
- 110V AC Outlet on platform with GFI
- Tilt alarm (5.0° x 5.0°) with drive and lift cut-out
- Single point emergency lowering
- Hourmeter
- Operator horn
- All motion alarm
- 360° Continuous turret rotation
- Tie down/lifting lugs
- Grip lug solid tires
- Telematics ready
- 2 Year Gold Leaf Warranty (5 year structural warranty)

ACCESSORIES

- Pipe rack
- Glazier kit
- Tool caddy

OPTIONS

- Flashing light
- 36 x 72" Platform
- Side spring hinged entry gate
- Auxiliary top rail (36 x 96" platform only)
- 3.5 kW generator
- Welder ready package
(Includes 7.5 kW generator, 3-phase power connection in platform, and welder mount)
- Welder package
(Includes 7.5 kW generator, 3-phase power connection in platform, welder mount, and Lincoln V275-S welder)
- Cold weather start kit*
*Recommended for regions where average monthly low temperatures can reach 14°F / -10°C (Includes cold start engine oil, battery blanket, and hydraulic tank heater)
- Arctic weather package*
*Recommended for regions where average monthly low temperatures can reach -0.4°F / -18°C (Includes arctic engine oil, battery blanket, hydraulic tank heater, block heater, arctic hydraulic oil, and arctic gear oil in the axles and swing drive. Glow plugs, arctic hydraulic hoses (all), arctic platform rotator and oversized foot switch cover are also included (standard equipment).)
- Control box cover
- Diesel scrubber for tier 4 final engine
- Positive air shut-off valve (diesel only)
- Bio oil
- Non destructive testing
- Grip lug foam-filled tires (SJ45 T+ only)
- Grip lug foam-filled non-marking tires (SJ45 T+ only)
- Grip lug solid non-marking tires
- ELEVATE telematics

† Standard lead times may be increased when optional equipment is added, consult factory.
‡ Capacities and machine weights may differ when options are added.

<< go back

**AERIAL
TITANS**

866-874-0584

WWW.AERIALTITANS.COM

SJ40/45 T+ TELESCOPIC BOOMS

Dimensions	SJ40 T+	SJ45 T+
Work Height	46' 7" (14.20 m)	51' 1.5" (15.58 m)
Platform Height	40' 7" (12.37 m)	45' 1.5" (13.75 m)
Horizontal Reach	33' 11" (10.34 m)	39' 8.25" (12.10 m)
A Platform Size	36" x 96" (0.91 x 2.44 m)	36" x 96" (0.91 x 2.44 m)
B Stowed Width	7' 6" (2.29 m)	7' 6" (2.29 m)
C Tailswing	3' 8" (1.12 m)	3' 8" (1.12 m)
D Stowed Height	7' 10.5" (2.40 m)	7' 10.5" (2.40 m)
E Transportation Height	-	9' 7" (2.92 m)
F Stowed Length	25' 4.25" (7.73 m)	28' 11.5" (8.83 m)
G Transportation Length	-	22' 11" (6.99 m)
H Wheelbase	8' (2.44 m)	8' (2.44 m)
I Ground Clearance	10.75" (0.27 m)	10.75" (0.27 m)
Specifications	SJ40 T+	SJ45 T+
Rotation	360° Continuous	
Platform Rotation	170°	
Jib Length	-	5' (1.52 m)
Jib Range +/-	-	+65° / -60°
Weight	14,805 lbs (6,715 kg)	15,780 lbs (7,160 kg)
Gradeability	40%	
Turning Radius (Inside)	7' 6" (2.24 m)	7' 6" (2.24 m)
Turning Radius (Outside)	17' (5.18 m)	17' (5.18 m)
Axle Oscillation	5" (12.70 cm)	5" (12.70 cm)
Drive Speed (High speed)	2.5 mph (4.0 km/h)	
Capacity	750 / 1,000 lbs (340 / 454 kg)	660 / 1,000 lbs (300 / 454 kg)
Maximum Wind Rating	28 mph (12.5 m/s)	28 mph (12.5 m/s)
Personnel Rating at Max Wind Rating	2 / 3	2 / 3
Tire Type	Solid	Solid
Diesel Engine	Kubota D1305 - 24.8 HP (18.5 KW)	
Fuel Tank Capacity	45 gal. (170 L)	
Hydraulic Reservoir	59 gal. (223 L)	

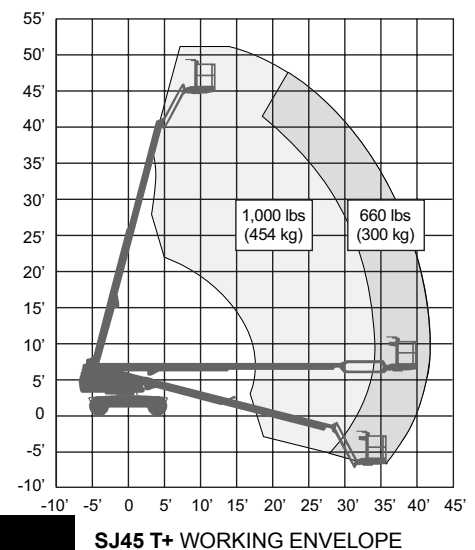
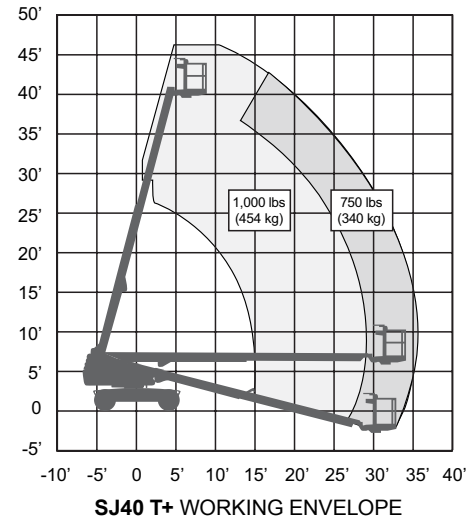
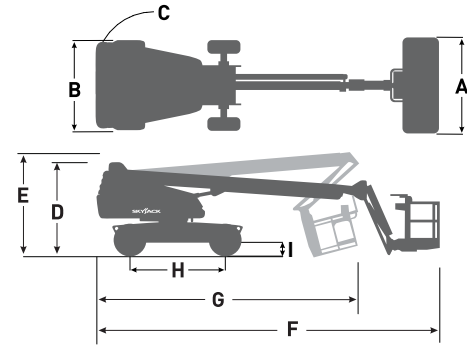

Skyjack Head Office
 55 Campbell Rd. Guelph, ON Canada N1H 1B9
 Sales Inquiries: 1-877-755-4387 (1-877-SJLIFTS)
 Main Switchboard: 1-800-265-2738
 Phone: 519-837-0888
 Fax: 519-837-8104
 Email: skyjack@skyjack.com

www.skyjack.com

**AERIAL
TITANS**

866-874-0584

WWW.AERIALTITANS.COM

SKYJACK
 simply reliable

This brochure is for illustrative purpose only and based on the latest information at the time of printing. Skyjack Inc. reserves the right to make changes at any time, without notice, to specifications, standard and optional equipment. Consult the Operating Maintenance and Parts Manuals for proper procedures. Work platforms have been tested to comply with ANSI and CSA standards as interpreted by Skyjack Inc.