

RT5394

ROUGH TERRAIN SERIES

SCISSOR LIFT

AERIAL TITANS

866-874-0584

WWW.AERIALTITANS.COM

<< go back



KEY SPECS

Platform Height

53-ft / 16.2-m

Machine Width

7-ft 7-in / 2.3-m

Platform Capacity

1,500-lb / 680-kg

Stowed Drive Speed

3.5 mph / 5.6 km/h

KEY FEATURES

- Our electric powered rough terrain models offer drive capability at full height, limiting unnecessary trips up and down for working professionals.
- This machine utilizes higher part commonality and a maintenance-free 2WD AC drive system for simplified service across the rough terrain family.
- Delivers the latest technology, featuring an LCD platform control box with LiftSense technology and USB charging for next-level, real-time productivity and service communication to the operator.
- This model is the tallest machine in its class, providing access to five-story heights.

ACCESSORIES & OPTIONS

- 1/2-in Airline to Platform
- 43.5-lb (19.7-kg) Propane Tank
- Cold Weather Start Kit
- Dual Extension Deck
- Flashing Amber Beacon
- Leveling Jacks
- Pipe Rack Accessory
- Platform Worklights
- SkyPower®
- SkyPower with SkyWelder
- Workstation

STANDARD SPECIFICATIONS

Performance

Platform Height (Elevated)	53-ft / 16.2-m
Platform Capacity	1,500-lb / 680-kg
Capacity on Platform Extension	500-lb / 227-kg
Number of Occupants	6
Lift / Lower Time	65/60 seconds
Maximum Drive Height	32-ft / 9.75-m
Weight w/One Extension*	17,000-lb / 7,711-kg
Ground Bearing Pressure	90 psi / 6.3 kg/cm ²
Drive Speed	3.5 mph / 5.6 km/h
Gradeability	40%
Max Tilt Rating (Side-to-Side)	1.5 Degrees
Max Tilt Rating (Fore and Aft)	1.5 Degrees
Turning Radius (Inside)	9-ft / 2.7-m
Turning Radius (Outside)	19-ft 9-in / 6.0-m

*Certain options or country standards increase weight

Engine

Dual Fuel – Kubota W6972	31 hp / 23 kW
Diesel Fuel – Kubota D1305	24.8 hp / 18.5 kW
Fuel Tank Capacity	22 gal / 83.3 L

Tires

Standard	12 x 16.5-in Foam-filled
----------	--------------------------

Brakes

Rear Wheel	Spring Applied
------------	----------------

Hydraulic System

Capacity	32 gal / 121.4 L
----------	------------------

STANDARD FEATURES

- 110V-AC Receptacle in Platform
- 4-ft (1.22-m) Manual Deck Extension
- 4-Wheel Drive
- 70.5 x 149.8-in (1.8 x 3.8-m), All Steel Platform with Aluminum Deck
- Adjustable, Removable Platform Control Station
- All Motion Alarm
- Automatic Transmission
- Fold-Down Handrails
- Horn
- Oscillating Axle
- Proportional Drive/Lift Up/Lift Down
- Three-speed Drive Select
- Tilt Light and Alarm

AERIAL TITANS

866-874-0584

WWW.AERIALTITANS.COM

RT5394

ROUGH TERRAIN SERIES

SCISSOR LIFT

AERIAL TITANS

866-874-0584

WWW.AERIALTITANS.COM

<< go back

DIMENSIONS

All dimensions are approximate

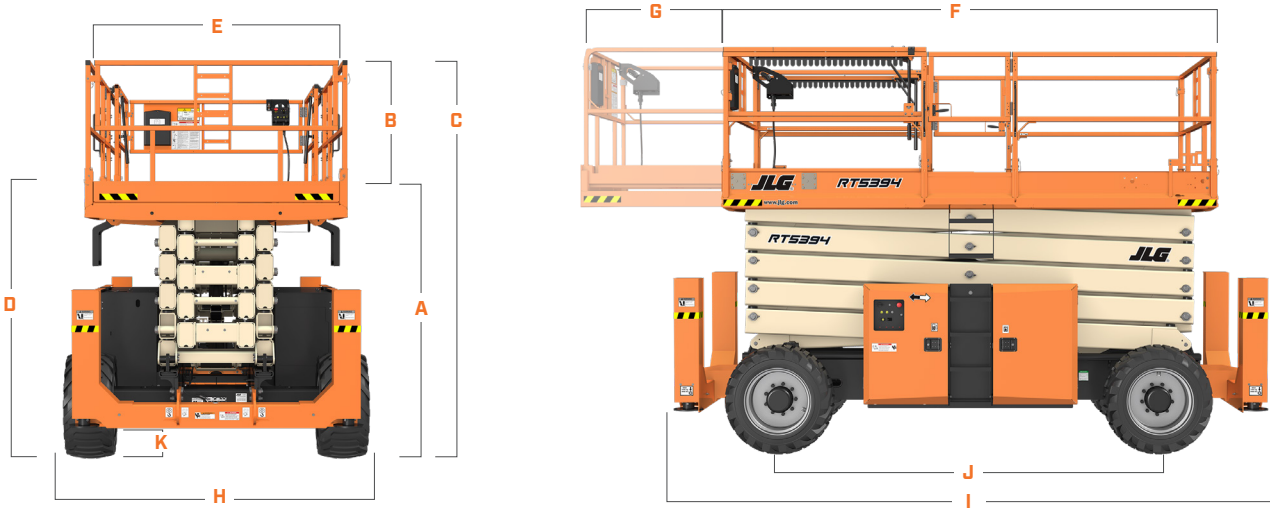

A. Platform Height (Lowered)	7-ft / 2.13-m	G. Platform Extension	4-ft / 1.2-m
B. Platform Railing Height	43.5-in / 1.1-m	H. Machine Width	7-ft 7-in / 2.3-m
C. Machine Height (Rails Raised)	10-ft 5-in / 3.2-m	I. Machine Length	16-ft / 4.9-m
D. Machine Height (Rails Lowered)	7-ft 9-in / 2.36-m	J. Wheelbase	9-ft 9-in / 3.0-m
E. Platform Width	70.5-in / 1.8-m	K. Ground Clearance	12-in / 30-cm
F. Platform Length	149.8-in / 3.8-m		



866-874-0584

WWW.AERIALTITANS.COM



We provide coverage for one (1) full year, and cover all specified major structural components for five (5) years. Due to continuous product improvements, we reserve the right to make specification and/or equipment changes without prior notification. This machine meets or exceeds applicable ANSI and CSA requirements based on machine configuration as originally manufactured for intended applications. Please reference the serial number plate on the machine for additional information.



JLG INDUSTRIES, INC.
Toll-free US 877-JLG-LIFT
JLG.com

An Oshkosh Corporation Company