

**AERIAL
TITANS**

866-874-0584

WWW.AERIALTITANS.COM

HT85 RTJ O



PERFORMANCE & PRODUCTIVITY

- > Among the industry's best horizontal outreach of 78 ft. 3 in.
- > Smooth and precise movements
- > Outstanding rough terrain capabilities
- > Dual load capacity 550 - 770 lb (optional)

SAFETY & COMFORT

- > Haulotte Activ'Lighting System (PRO model) for loading / unloading in low visibility conditions
- > Ultimate control & comfort is engineered to provide superior working-envelope efficiency
- > Robust boom design
- > Haulotte Activ'Shield Bar (optional)

MAXIMIZED TOTAL COST OF OWNERSHIP

- > Haulotte Activ'Screen on-board diagnostic system
- > Haulotte Stop Emission System regulates engine run time, reducing fuel consumption, pollution and noise
- > Easy access to all components
- > Modular platform, quick and easy to repair

HT85 RTJ O

<< go back

ROUGH TERRAIN TELESCOPIC BOOMS

TECHNICAL DATA

HT85 RTJ O

Working height	91 ft
Platform height	85 ft
Horizontal outreach	78 ft 3 in
Below grade reach	9 ft 8 in
Lift capacity	500 lb (2 pers.) - option 770 lb
F x G Platform size	8 ft x 3 ft
A Length - stowed	42 ft 1 in
H Length - storage	32 ft 2 in
B Width	8 ft 2 in
C Height - stowed	9 ft 4 in
I Height - storage	9 ft 9 in
Vertical jib rotation	133° (- 66° / + 67°)
Jib length	6 ft
Turret swing	360° continuous
Tailswing	60 in
D Wheelbase	9 ft 2 in
E Ground clearance	19 in
Tilt alarm	4 °
Drive speed	0.3 - 3.1 mph
Gradeability	45 %
Turning radius - outside	21 ft 6 in
Engine	Kubota, 53 kW (72hp), Tier 4 final
Weight	39 500 lbs

STANDARD EQUIPMENT

- > Haulotte Stop Emission System
- > Haulotte Activ'Screen
- > Universal telematics plug
- > 4 wheel drive / 2 wheel steer (O) or 4 wheel steer (PRO)
- > Oscillating axle
- > Smooth & proportional movements
- > Automatic wheel differential lock
- > Upper control box protection cover and tool tray in ultra-rugged composite
- > Large modular platform 8 ft. x 3 ft.
- > Drop bar entry gate
- > Basket rotation 180° (+90°/-90°)
- > Swing-out engine tray for easy maintenance access
- > Sound and light alarm for tilt and load
- > Movement alarm and rotating beacon light

OPTIONS AND ACCESSORIES

- > Haulotte Activ'Lighting System Safe Load (O model)
- > Haulotte Activ'Shield Bar 2.0 (O model)
- > Non-marking tires - Sand / Turf High Flotation tires (only on O model)
- > Dual load capacity 500 - 770 lbs (2 persons)
- > 37 mph wind speed
- > Power to platform (Female plug 110 V / 220 V)
- > Air line to platform 1/2 in inside diameter
- > Lateral swing door entry gate
- > Hydraulic generator 3.5 kW, 6.5 kW or 12 kW
- > Hydraulic oil cooler
- > Cold and Arctic weather kits
- > Glazier kit - Welder kit
- > Pipe cradle kit
- > Motion flashing warning light
- > Battery circuit breaker

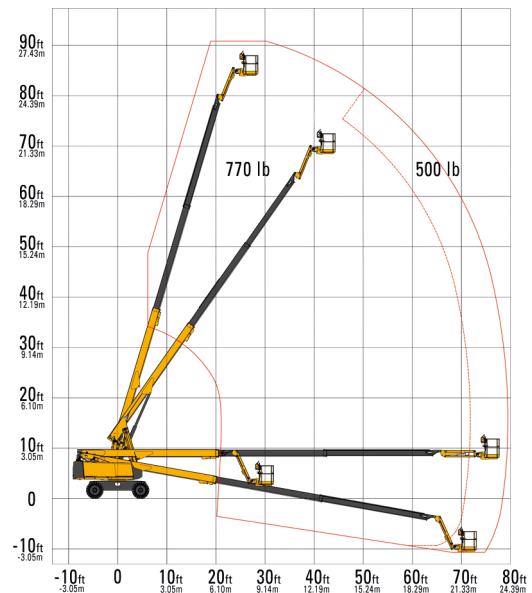
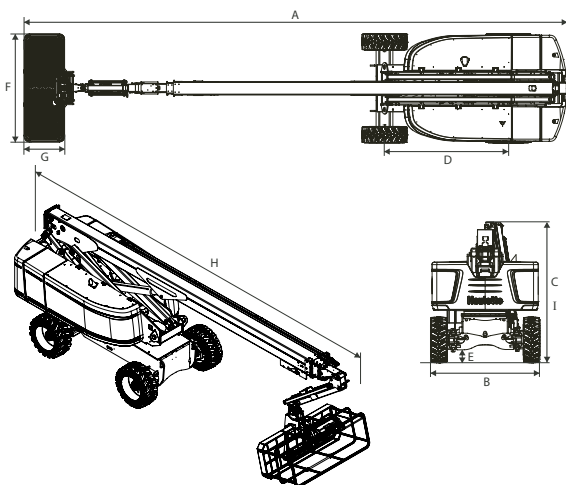

4000514240 - Non contractual document - We reserve the right to modify the technical characteristics of this document without notice - 04/2019