

# HT46 RTJ PRO



**AERIAL  
TITANS**  
866-874-0584  
WWW.AERIALTITANS.COM

## GREAT PRODUCTIVITY & PERFORMANCE

- > Dual load capacity: 550 lbs - 770 lbs restricted (standard)
- > 4 wheel drive for excellent rough terrain capabilities
- > Quick & simultaneous movements
- > 4 wheel steer for agile maneuverability

## MINIMIZED TOTAL COST OF OWNERSHIP

- > Easy access to components
- > Haulotte Activ'Screen diagnostic display for onboard fault & service alerts
- > Haulotte Stop Emission System reduces engine and component wear
- > Engine and drive train optimizes all-terrain performance

## OPTIMAL SAFETY

- > Haulotte Activ'Shield Bar prevents crushing risks
- > Haulotte Activ'Lighting System illuminates the machine for safe loading in low visibility
- > Smooth & proportional movements for greater precision



**AERIAL  
TITANS** 866-874-0584  
WWW.AERIALTITANS.COM

# HT46 RTJ PRO

<< go back

## ROUGH TERRAIN TELESCOPIC BOOMS

### TECHNICAL DATA

Working height	52 ft
Platform height	46 ft
Horizontal outreach	42 ft 8 in
Lift capacity	550 lb (2 pers.) - option: 770 lb
<b>F</b> x <b>G</b> Platform size	8 ft x 3 ft
<b>A</b> Length - stowed	30 ft 1 in
<b>H</b> Length - storage	21 ft 11 in
<b>B</b> Width	7 ft 6 in
<b>C</b> Height - stowed	8 ft 1 in
Height - storage	10 ft
Vertical jib rotation	133° (- 65° / + 68°)
Jib length	5 ft 11 in
Turret swing	360° continuous
Tailswing	37 in
<b>D</b> Wheelbase	7 ft 9 in
<b>E</b> Ground clearance	13 in
Tilt alarm	5 °
Drive speed	3.2 mph
Gradeability	45 %
Turning radius - outside	11 ft 10 in
Engine	Kubota, 18,5 kW, Tier 4 final
Weight	17 486 lb

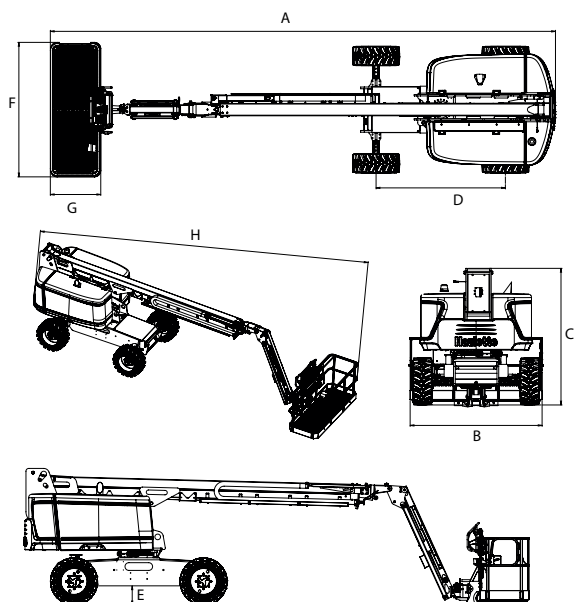

### STANDARD EQUIPMENT

- > Haulotte Activ'Shield Bar
- > Haulotte Activ'Lighting System: improved visibility
- > Haulotte Stop Emission System: automatically turns the engine off & on
- > Haulotte Activ'Screen: on-board diagnostics
- > 4 Wheel drive
- > 4 Wheel steer
- > Oscillating axle
- > Differential: permanent limited slip & operator controlled locking rear
- > Smooth & proportional movements
- > Up to 4 cumulated movements
- > Telematics-ready connector
- > Cured-on solid tires
- > Swing out engine tray
- > Upper control box protection and tool tray
- > Sound and light alarm for tilt and load
- > All motion alarm and flashing beacon

### OPTIONS AND ACCESSORIES

- > Dual load basket capacity 550 - 770 lbs restricted (standard in North America)
- > Large platform 8 ft x 3 ft (standard in North America)
- > Swing door entry gate (standard in North America)
- > Power to platform with plug in the basket (standard in North America)
- > Hydraulic generators 3,5kw or 6,5kw
- > Glazier pack
- > Pipe rack kit
- > Air-line to platform
- > Dual USB plug in basket
- > Non-marking tires
- > Cold weather package
- > Hydraulic oil cooler

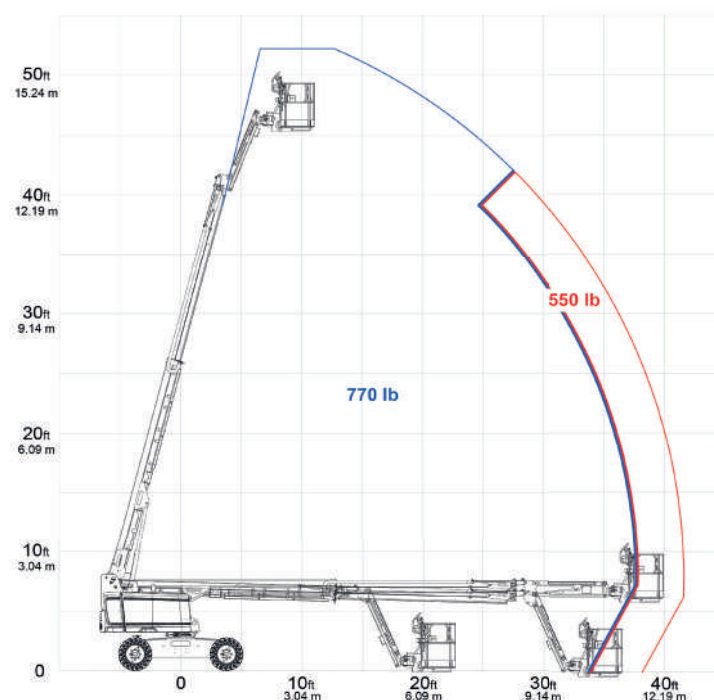

4001076070 - Non contractual document - We reserve the right to modify the technical characteristics of this document without notice - 01/2020