

**AERIAL
TITANS**

866-874-0584
WWW.AERIALTITANS.COM

[<< go back](#)

HA61 RTJ PRO



PERFORMANCE & EASE OF USE

- > Rapid lifting speed of 48 sec.
- > Industry leading working envelope with an outreach of 40 ft
- > Fully proportional and simultaneous movements
- > Ease of transport

ROBUST & RELIABLE

- > Rugged hoods with ergonomic handle
- > Long lasting structural design

MAXIMIZED TOTAL COST OF OWNERSHIP

- > Haulotte Activ'Screen (on board diagnostic)
- > Haulotte Stop Emission System: automatically turns on / off the engine
- > Exclusive modular basket with upper control box cover and tool tray
- > Easy access to all components

SAFETY & SECURITY

- > Haulotte Activ'Shield Bar 2.0

[<< go back](#)

ROUGH TERRAIN ARTICULATING BOOMS

TECHNICAL DATA

HA61 RTJ PRO

Working height	67 ft 7 in
Platform height	61 ft
Horizontal outreach	40 ft
Up and over height	27 ft 7 in
Lift capacity	500 lb (2 pers.)
F x G Platform size	8 ft x 3 ft
A Length	28 ft 10 in
B Width	7 ft 11 in
Height - stowed	8 ft 3 in
H Transport length	21 ft 4 in
C Transport height	9 ft 7 in
Vertical jib rotation	140° (+ 60° / - 80°)
Platform rotation	180° (+ 90° / - 90°)
Turntable rotation	360° continuous
Tailswing	5.6 in
D Wheelbase	8 ft
E Ground clearance	16 in
Tilt alarm	5°
Drive speed	0.3 - 3.1 mph
Gradeability	45 %
Tires - solid rough terrain	40.4 x 14.4 in
Turning radius - outside	9 ft 10 in
Engine	Kubota 48.6kW, 66hp, Tier 4f
Weight	21,165 lbs

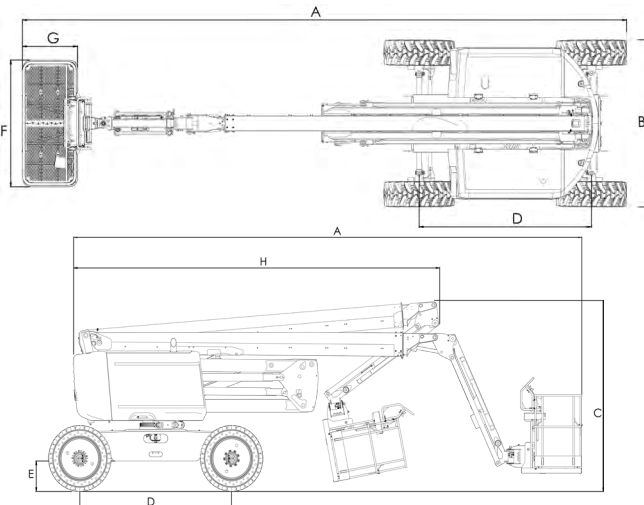

STANDARD EQUIPMENT

- > Haulotte Activ'Screen
- > Haulotte Activ'Shield Bar 2.0
- > Haulotte Stop Emission System
- > Universal telematics plug
- > Rotating beacon
- > Front oscillating axle increases stability on uneven ground
- > 4 wheel drive, 4 wheel steer
- > Permanent limited slip differential
- > 4 simultaneous movements for maximum productivity
- > Modular standard platform 8 ft x 3 ft, Drop bar entry gate
- > Upper control box protection cover and tool tray in ultra-rugged composite
- > AC power to platform 110 / 230 V
- > Travel alarm
- > Electric pump system and emergency descent
- > 12 V battery
- > Sound and light alarm for tilt and load
- > Hour meter
- > Low fuel level indicator (upper & lower control boxes)
- > Swing out engine tray for ease of maintenance

OPTIONS AND ACCESSORIES

- > Glazier kit
- > Non-marking tires
- > Biodegradable hydraulic oil
- > Warm weather kit: hydraulic oil cooler + hydraulic oil
- > Cold weather kit: 14°F / -13°F
- > Flashing light
- > Power to platform 110 / 230 V (with or without circuit-breaker 30mA)
- > 55 W working light
- > Air-line to platform .25 in inner diameter
- > Hydraulic generator Dynaset 3.5 Kw
- > Lateral swing door entry gate
- > Large modular platform 8 ft x 3 ft (Standard in North America)
- > Spark arrestor and check valve

