



HA46 RTJ PRO



PERFORMANCE & EASE OF USE

- > Industry leading working envelope with an outreach of 27 ft 3 in
- > Rapid lifting speed of 40 sec
- > Fully proportional and simultaneous movements
- > 4-wheel steer and 360° continuous rotation for greater productivity

COMFORT AND SAFETY

- > Haulotte Activ'Shield Bar 2.0
- > Haulotte Activ'Lighting System for safe loading/unloading in low visibility conditions

MINIMIZED TOTAL COST OF OWNERSHIP

- > Haulotte Activ'Screen (on board diagnostics)
- > Haulotte Stop Emission System: automatically turns the engine on & off
- > Easy access to all components



866-874-0584
WWW.AERIALTITANS.COM

TECHNICAL DATA

HA46 RTJ PRO

Working height	51 ft 11 in
Platform height	45 ft 11 in
Horizontal outreach	27 ft 3 in
Up and over height	25 ft 1 in
Lift capacity	500 lb (2 persons)
F x G Platform size	95 in x 34.5 in
A Length	22 ft 2 in
H Transport length	16 ft 7 in
B Width	7 ft 7 in
C Height - stowed	7 ft 7 in
I Transport height	7 ft 10 in
Vertical jib rotation	140° [-80°/+60°]
Platform rotation	165° [-75°/+90°]
Turntable rotation	360° continuous
Tailswing	4 in
D Wheelbase	6 ft 11 in
E Ground clearance	15 in
Tilt alarm	5 °
Drive speed	3.2 mph
Gradeability	40 %
Turning radius - outside	12 ft 4 in
Tires - solid rough terrain	33.5 x 13.4 in
Engine	Kubota, 18.5kW (25hp),T4f
Weight	14,663 lb

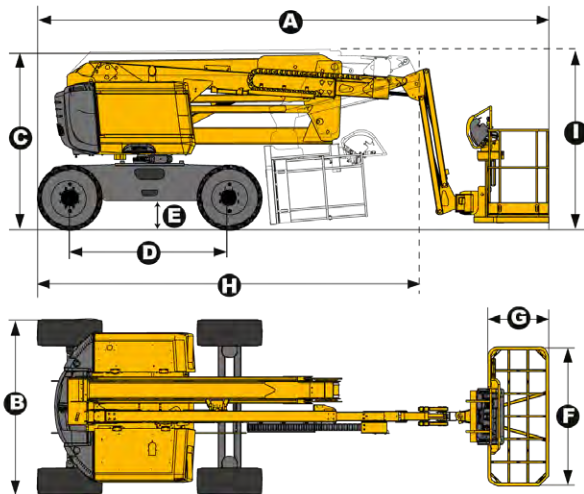

STANDARD EQUIPMENT

- > Haulotte Activ'Shield Bar 2.0
- > Haulotte Stop Emission System
- > Haulotte Activ'Lighting System
- > Onboard Haulotte Activ'Screen diagnostics on lower control box, with color screen
- > Universal telematics plug
- > 4 wheel drive
- > 4 wheel steer
- > Front oscillating axle increases stability on rough terrain
- > 4 simultaneous movements for maximum productivity
- > Permanent limited slip differential
- > Upper control box cover
- > Tool tray
- > 500 lb (2 persons) load capacity
- > Modular standard basket 72 in x 30 in, quick & easy to repair
- > Drop bar entry gate
- > AC power to platform (110 / 230 V)
- > Swing out engine tray for ease of maintenance
- > Sound and light alarm for tilt and load
- > Rotating beacon
- > Travel alarm
- > Hour meter
- > 12 V battery / electrical control system
- > Engine pre-heater with light indicator
- > Low fuel level indicator (upper & lower control boxes)
- > Electric emergency descent pump system

OPTIONS AND ACCESSORIES

- > Large cured on solid rough terrain tires 1025 x 365
- > Non-marking tyres 14 x 17.5
- > Modular large basket 8 ft x 3 ft, quick and easy to repair
- > Power to platform (female plug in the basket with or without circuit-breaker 30 mA)
- > Air-line to platform 0.25 in inside diameter
- > Lateral swing door entry gate
- > Hydraulic generator Dynaset 3.7Kw
- > Biodegradable hydraulic oil
- > Warm weather kit: hydraulic oil cooler + hydraulic oil
- > Cold weather kit : 14°F / - 13°F
- > Spark arrestor and electric one-way valve
- > Platform work lights
- > Battery cut-off

