

<< go back



Telehandler

GTH™-636



[click to return to website](#)

Specifications

Model	GTH™-636	
Measurements	US	Metric
Maximum lift height	36 ft	10.97 m
Maximum forward reach	21 ft 11 in	6.68 m
Reach at maximum height	1 ft 10 in	0.56 m
A Height, stowed	7 ft 10 in	2.39 m
B Length, stowed (without forks)	17 ft 10 in	5.44 m
Width	7 ft 11 in	2.41 m
C Wheelbase	10 ft 11 in	3.33 m
D Ground clearance, center	1 ft 3 in	0.38 m
E Ground clearance, axle	1 ft 5 in	0.43 m
Fork cross section	2 x 4 in	51 x 101 mm

Productivity

Maximum lift capacity	6,000 lbs	2,722 kg
Lift capacity at maximum height	5,000 lbs	2,268 kg
Lift capacity at maximum reach	1,500 lbs	680 kg
Drive speed	18 mph	29 km/h
Boom up/down	10/8 sec	10/8 sec
Boom extend/retract	11/9 sec	11/9 sec
Draw bar pull	15100 lbs	6849 kg
Turning radius, outside (4WS)	13 ft 4 in	4.06 m
Auxiliary hydraulic flow	2-15 gpm	7.57-56.8 lpm
Auxiliary hydraulic pressure	3,000 psi	206.8 bar
Tires, standard size	13 x 28 in, 12 ply	

Power

Power source	Deutz TD 2.9 L4 turbo charged diesel, Tier 4f 74 hp (55.2 kW)	
Electrical system	System voltage 12 volt Alternator 95 amp 1000 CCA at 0°F (-18°C)	
Hydraulic tank capacity	34.0 gal	128.7 L
Hydraulic system capacity (w/tank)	46.5 gal	176.0 L
Fuel tank capacity	27.0 gal	102.2 L

Weight*

	17,600 lbs	7,983 kg
--	------------	----------

Standards Compliance

ANSI/ITSDF B56.6, CSA B335

* Weight will vary depending on options and/or country standards.

** Load ratings vary depending on attachment.

Load Chart GTH™-636**

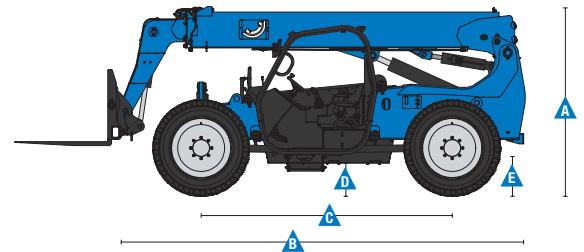
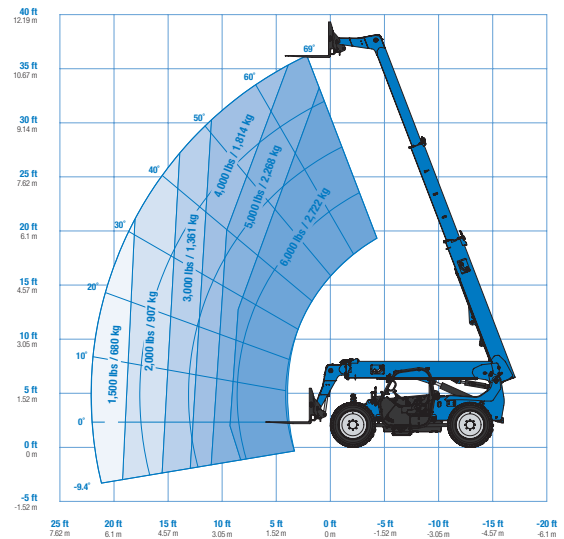

<< go back

AERIAL TITANS
866-874-0584
WWW.AERIALTITANS.COM

Features

Standard Features

Measurements

- 6,000 lb (2,722 kg) maximum lift capacity
- 36 ft (10.97 m) maximum lift height
- 21 ft 11 in (6.68 m) maximum reach

Productivity

- Full time 4WD
- 4WS
- Operator selectable front, crab, coordinated steering modes
- 3-speed forward and reverse powershift transmission
- Proportional frame leveling 10° each side
- Power assisted steering
- Inboard wet disc service brakes
- Wet disc spring applied parking brake
- 13 x 28 in 12-ply air filled rough terrain tires
- Front axle differential lock
- High efficiency/variable displacement hydraulic pump
- ROPS/FOPS canopy
- Single, multi-function, proportional joystick
- Machine level indicator
- Full gauge cluster with engine diagnostics
- Right-side screen standard on open cab
- Genie manual Quick-Attach™ system
- Retractable 3 in (7.6 cm) seatbelt
- Boom angle indicator
- 10 micron hydraulic return filter
- 1,000 cold cranking amps at 0° F (-18° C)
- Reverse motion alarm
- Adjustable suspension seat
- Auxiliary hydraulic circuit (15 GPM)
- Lifting shackle at boom tip
- Fenders (set of 4)
- Telematics Ready
- Rigging tray

Options & Accessories

Productivity Options

- Fully enclosed cab (includes full glass, defroster, wiper, right-side sliding window, split door, washer)
- Fully enclosed cab with air conditioning
- Flashing beacon
- Work lights (High output LED cab, boom and rear)
- Road lights (High output LED 2 front mounted, 1 backup, 2 rear stop/turn/tail)
- Fire extinguisher
- Front and top glass
- Rear proximity alarm

Engine Options

- Deutz TD 2.9 L4 turbo charged diesel, Tier 4f 74 hp (55.2 kW)*
- Electric block heater

Tire Options

- 13 x 28 in 12-ply foam-filled rough terrain tires
- 13 x 24 in solid rough terrain tires
- 14 x 28 in 12-ply foam-filled hard surface tires

Options & Accessories

Attachment Options

- Carriages
 - 60 in (1.52 m) carriage
 - 72 in (1.83 m) carriage
 - 48 in (1.22 m) rotating carriage (10° from center left and right)
 - 60 in (1.52 m) rotating carriage (10° from center left and right)
 - 72 in (1.83 m) swing carriage (45° from center left and right)
- Forks
 - 60 in (1.52 m) pallet forks (set of two) 2 x 4 x 60 in (.05 x .10 x 1.52 m)
 - 72 in (1.83 m) pallet forks (set of two) 2 x 4 x 72 in (.05 x .10 x 1.83 m)
 - 60 in (1.52 m) lumber forks (set of two) 1.75 x 7 x 60 in (.04 x .18 x 1.52 m)
 - 48 in (1.22 m) cubing tines (set of four) 2 x 4 x 48 in (.05 x .10 x 1.22 m)



**AERIAL
TITANS**

866-874-0584

WWW.AERIALTITANS.COM

Genie United States

6464 185th Ave. NE
Redmond, WA 98052
Telephone +1 (425) 881-1800
Toll Free in USA/Canada +1 (800)-536-1800
Fax +1 (425) 883-3475

Distributed By: