

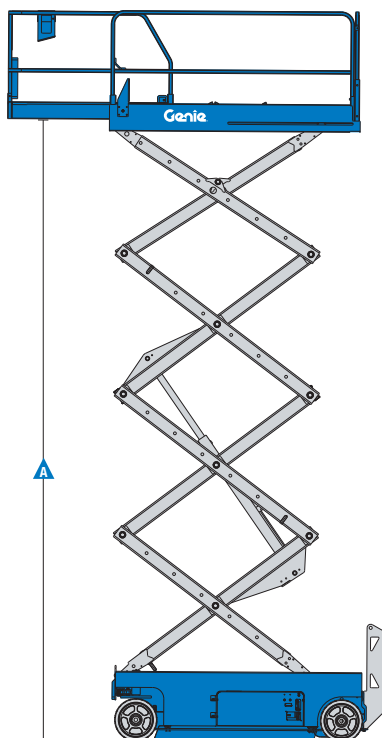

A TEREX BRAND

Self-Propelled Scissor Lifts

GS™ -4046 E-drive

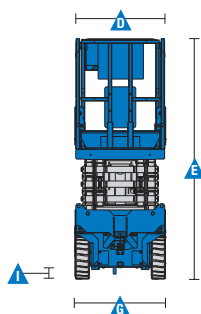
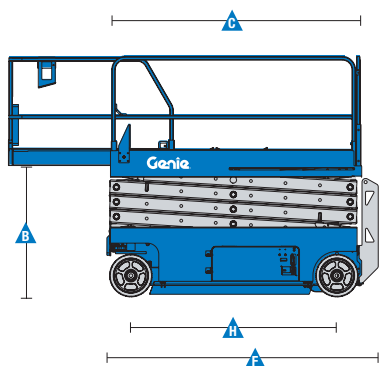

Specifications

Model	GS-4046	
Measurements	US	Metric
Working height maximum - indoor ¹	45 ft 2 in	13.94 m
- outdoor ¹	29 ft	9.01 m
A Platform height maximum - indoor	39 ft 2 in	11.94 m
- outdoor	23 ft	7.01 m
B Platform height - stowed	4 ft 9 in	1.45 m
C Platform length - outside	7 ft 5 in	2.26 m
- extended	10 ft 5 in	3.18 m
D Platform width - outside	3 ft 10 in	1.16 m
E Height - stowed with folding rails raised	8 ft 5 in	2.57 m
- stowed with rails lowered	6 ft 6 in	1.98 m
F Length - stowed	8 ft 2 in	2.48 m
- extended	11 ft 6 in	3.51 m
G Width	3 ft 10 in	1.18 m
H Wheelbase	6 ft 1 in	1.85 m
I Ground clearance - center	5 in	12 cm
- with pothole guards deployed	0.9 in	2.29 cm
Roll-out platform extension deck	3 ft	0.91 m
Guardrail height	3 ft 7 in	1.1 m
Toeboard height	6 in	15 cm

Productivity

Max platform occupancy (in/out)	3/1	
Lift capacity	770 lbs	350 kg
Lift capacity - extension deck	250 lbs	113 kg
Drive height	Full height	
Drive speed - stowed	2.0 mph	3.2 km/h
Drive speed - raised	0.5 mph	0.8 km/h
Gradeability - stowed ²	25%	
Turning radius - inside	zero	
Turning radius - outside	7 ft 6 in	2.29 m
Raise/lower speed	71/41 sec	
Tilt sensor activation - front to back	3°	
- side to side	1.5°	
Controls	proportional	
Drive	dual AC electric drive, front wheel	
Brakes	dual electric, front wheel	
Tires solid non-marking	15 x 5 in	38 x 13 cm

Power

Power source	24 V DC, 210 Ah (four 12V, 210 Ah batteries)	
Hydraulic system capacity	4.9 gal	18.5 L

Weight³ / Floor Loading⁴

Weight - ANSI/CSA/CE	6,871 lbs	3,117 kg
Tire load, maximum:	2,735 lbs	1,241 kg
Tire contact pressure:	170.3 psi	1,174 kPa
Occupied floor pressure:	275 psf	13.17 kPa

Standards Compliance ANSI A92.20, CSA B354.6, CE EN280, AS 1418.10



Self-Propelled Scissor Lifts

GS™ -4046 E-drive

Features

Standard Features	Standard Features	Options & Accessories
-------------------	-------------------	-----------------------

Measurements

GS-4046

- 45 ft 2 in (13.94 m) working height
- Up to 770 lbs (350 kg) lift capacity

Productivity

- Drive at full height
- Folding rails with full height swing gate
- SmartLink™ - dual zone control
- Proportional lift and drive
- Platform load sense system
- Platform control guard
- Platform control with battery charge indicator
- AC power to platform
- Universal 27A smart charger
- Lanyard attachment points
- Manual platform lowering valve
- Emergency stop at both platform and ground controls
- Dual front wheel AC electric drive motors (E-drive)
- Dual front wheel electric brakes
- Electric & manual brake release
- Swing-out component trays
- Pothole guards
- Tilt level sensor with audible alarm
- Dual flashing LED beacons
- Descent alarm
- Electronic horn
- Hour meter
- Motion alarm
- Tech Pro™ Link compatible
- Side & rear forklift pockets
- Maintenance free steel diamond plate platform

Power

- 24 V DC, 210 Ah (four 6 V 105 Ah batteries)
- Universal 27 amp smart charger

Platform

- 7 ft 5 in x 3 ft 9.3 in (2.26 x 1.15 m) steel platform
- 3 ft 9.3 in (0.91 m) extension deck

Drive

- Dual front wheel AC electric drive (E-drive)

Tires

- Solid non-marking

Productivity Options

- Air line to platform
- Automotive-style horn
- Lift Tools™ Pipe Cradle
- Lift Tools Panel Cradle
- Lift Tools Work Tray
- Lift Guard™ Contact Alarm
- Lift Connect™ Telematics

Power Options

- Power inverter (120 V / 60 Hz)¹
- Drive cutout while charging



<< go back

AERIAL TITANS

866-874-0584

WWW.AERIALTITANS.COM

¹ Not available with EE rating

Genie United States

6464 185th Ave. NE
 Redmond, WA 98052
 Telephone +1 (425) 881-1800
 Toll Free in USA/Canada +1 (800)-536-1800
 Fax +1 (425) 883-3475

Distributed By:



Effective Date: October, 2020. Product specifications and prices are subject to change without notice or obligation. The photographs and/or drawings in this document are for illustrative purposes only. Refer to the appropriate Operator's Manual for instructions on the proper use of this equipment. Failure to follow the appropriate Operator's Manual when using our equipment or to otherwise act irresponsibly may result in serious injury or death. The only warranty applicable to our equipment is the standard written warranty applicable to the particular product and sale and we make no other warranty, express or implied. Products and services listed may be trademarks, service marks or trade names of Terex Corporation and/or their subsidiaries in the USA and many other countries. Terex, Genie and AWP are registered trademarks of Terex Corporation or its subsidiaries. © 2020 Terex Corporation.