

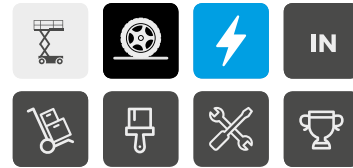

COMPACT 3947 E



EXCEPTIONAL PRODUCTIVITY

- > 44 ft 11 inch working height
- > Driveable at full height
- > Load capacity: 770 lbs
- > Reliable and easy to maintain
- > 3 foot platform extension
- > Longer duty cycles

OPTIMAL COMPACT DIMENSIONS

- > 47 inch width
- > Folding guardrails

**AERIAL
TITANS**

866-874-0584

WWW.AERIALTITANS.COM

ELECTRIC SCISSOR LIFTS

TECHNICAL DATA

COMPACT 3947 E

Working height	44 ft 11 in
Platform height	38 ft 11 in
Lift capacity - inside	770 lb (3 pers.)
Lift capacity - extension	330 lb
Driveable at full height up to	38 ft 11 in
A Platform length - outside	7 ft 7 in
Platform length - extended	10 ft 7 in
Extension length	3 ft
Platform width - outside	3 ft 11 in
D Storage height	6 ft 10 in
C Height - stowed	8 ft 2 in
B Overall width	3 ft 11 in
E Length	8 ft 2 in
F Wheelbase	6 ft 1 in
G Ground clearance	6 in
Ground clearance - pothole guards deployed	1 in
Drive speed	0.6 - 1.7 mph
Gradeability	23 %
Tilt alarm	2° / 3°
Turning radius - outside	8 ft 2 in
Non-marking tires	15x5
Batteries	24 V - 340 Ah (C20)
Hydraulic system capacity	7 gal
Weight	7,236 lbs
Driveable at full height up to	38 ft 11 in

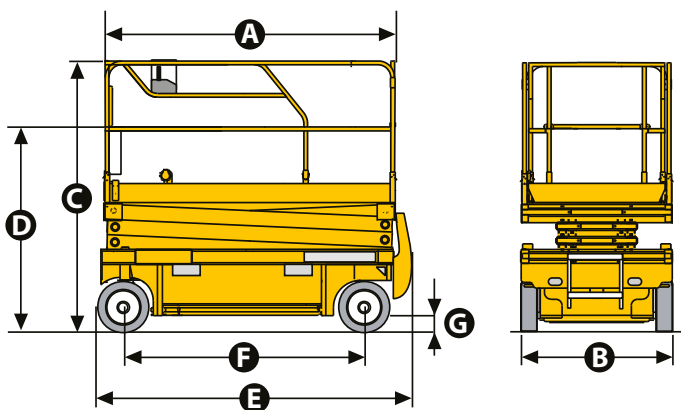

STANDARD EQUIPMENT

- > Battery charger 110 V / 60 Hz
- > Battery charge indicator
- > Integrated forklift pockets
- > Pothole protection
- > Proportional lift and drive
- > Front wheel steer & drive wheels
- > Non-marking tires
- > Brake release
- > Swing out component tray
- > Load management system in the platform
- > Tilt alarm
- > Hourmeter
- > Horn
- > Removable control box in platform
- > Manual platform lowering valve
- > Towing hooks

OPTIONS AND ACCESSORIES

- > Power to the platform
- > Swing door entry gate (standard in North America)
- > Biodegradable hydraulic oil
- > Centralized battery filling
- > Flashing beacon
- > Working light

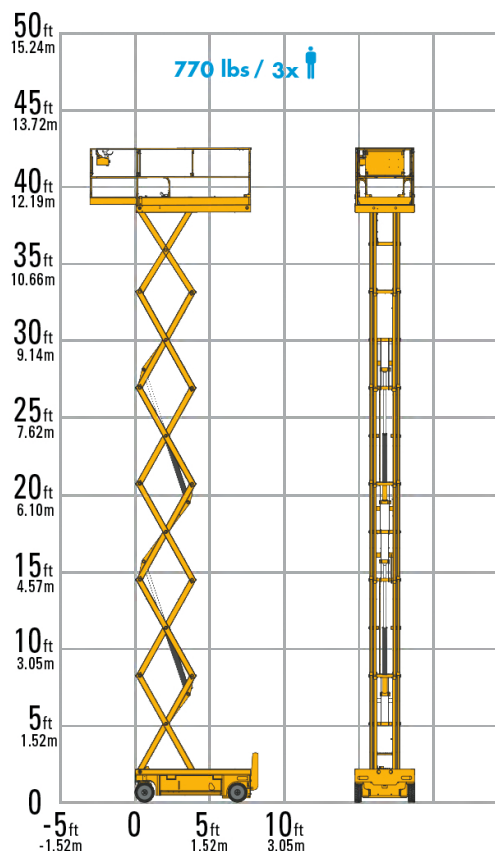

4.00007614.0 - Non-contractual document - We reserve the right to modify the technical characteristics of this document without notice - 03/2019