

800 SERIES

TELESCOPIC BOOM LIFTS

<< go back

Performance

Platform Height—Elevated		
800S	80 ft	24.38 m
860SJ	86 ft	26.21 m
Horizontal Outreach		
800S	71 ft	21.64 m
860SJ	75 ft	22.86 m
Swing	360° Continuous	
Platform Capacity—		
Restricted (800S)	1,000 lb	454 kg
Restricted (860SJ)	750 lb	340 kg
Platform Capacity—		
Unrestricted	500 lb	227 kg
Platform Rotator	180° Hydraulic	
Jib Range of Articulation		
860SJ	130°	+70, -60
Weight ¹		
800S	33,030 lb	14,982 kg
860SJ	36,888 lb	16,732 kg
Max. Ground Bearing Pressure		
800S	72 psi	5.06 kg/cm ²
860SJ	81 psi	5.69 kg/cm ²
Drive Speed 2WD	3.5 mph	5.6 kmph
Drive Speed 4WD	3.5 mph	5.6 kmph
Gradeability 2WD	25%	
Gradeability 4WD	45%	
Tilt Cut Out	4°	
Turning Radius		
Inside	12 ft 6 in.	3.8 m
Outside	19 ft 8 in.	6.02 m

1. Certain options or country standards will increase weight.

Standard Specifications

Engine

Dual Fuel Engine, Ford MSG425-DF	84 hp	62.6 kW
Diesel Engine, Deutz TD2.9L4 Tier 4 Final	67 hp	50 kW
Fuel Tank Capacity	31 gal	117.3 L

Hydraulic Reservoir

Capacity	48 gal	181.7 L
Pump	Fixed Displacement Gear	

Tires

Standard	15-625 Foam Filled Lug Tread	
Optional	Sand/Turf Foam Filled Tires	
	18-625 Foam Filled Tires	
	18-625 Non Marking Foam Filled Tires	



Standard Features

- SkyGuard SkyLine™
- Hydrostatic Drive
- 6 ft (1.83 m) Articulating Jib (860SJ Only)
- Dual-Rated Capacities
- Platform: 36 x 96 in. (0.91 x 2.44 m) Side Entry
- Oscillating Axle
- Glow Plugs (Diesel Engines)
- Hydraulic Platform Rotator
- 110V AC Receptacle in the Platform
- Swing-Out Engine Tray
- 4 Degree Tilt Alarm/Indicator Light
- 12V DC Auxiliary Power
- Hourmeter
- Fuel Gauge
- Control ADE™ System
- All Motion Alarm
- Proportional Controls
- Gull-Wing Hoods
- Load Sensing System
- Platform Console Machine Status Light Panel*
- Engine Distress Warning/Shutdown—Selectable via JLG Analyzer

* Provides indicator lights at platform control console for system distress, fuel level, low fuel, 5 degree tilt light and foot switch status.

Accessories & Options

- SkySense™
- Platform: 36 x 72 in. (0.91 x 1.83 m)
- Light Package¹
- Fall Arrest Platform
- Soft-Touch System
- Flashing Amber Beacon
- Catalytic Muffler
- Cold Weather Start Kit²
- Hostile Environment Kit³
- Arctic Package⁴
- Tow Package
- Operators Tool Tray
- Lifting/Tie Down Lugs
- Special Hydraulic Oils (Consult Factory)
- Accessory Packages:
 - SkyWelder®
 - SkyPower®

1. Includes platform mounted work lights, drive/backup lights and beacon.

2. Engine block heater, battery heater and oil tank heater.

3. Includes console cover, boom wipers and cylinder bellows.

4. Includes arctic hydraulic hoses (drive and steer only and main boom cable, arctic hydraulic oil, extreme cold engine oil, anti-freeze)

Additional accessories and options available via JLG Aftermarket.

800 SERIES

TELESCOPIC BOOM LIFTS

AERIAL TITANS

866-874-0584

WWW.AERIALTITANS.COM

Dimensions

<< go back

All dimensions are approximate.

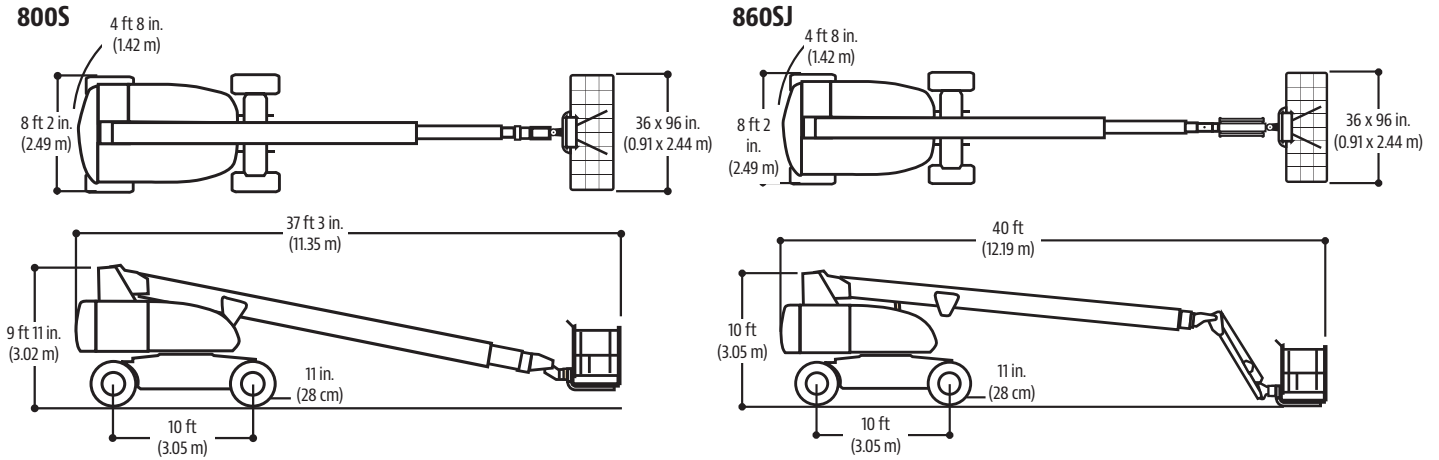

Reach Diagrams

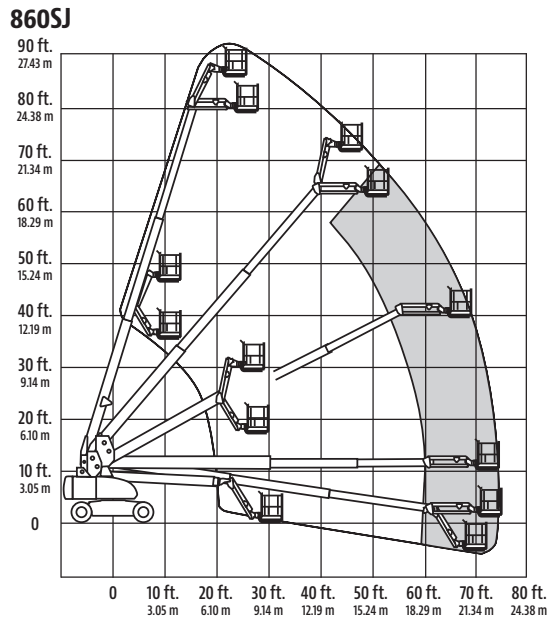
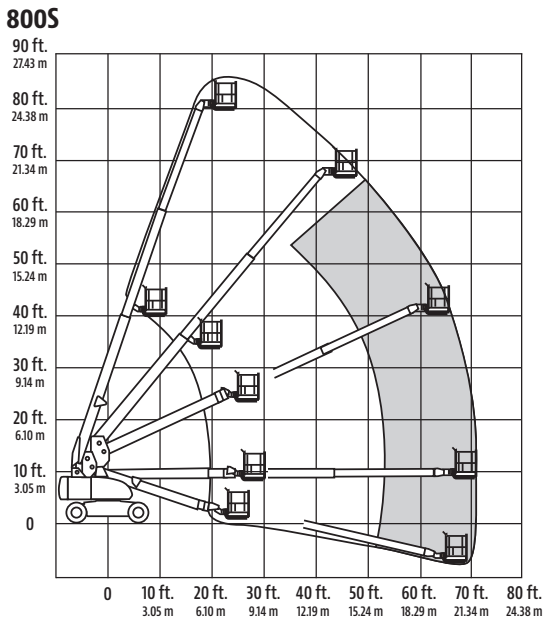

866-874-0584
WWW.AERIALTITANS.COM



The JLG "1 & 5" Warranty

We provide coverage for one (1) full year, and cover all specified major structural components for five (5) years. Due to continuous product improvements, we reserve the right to make specification and/or equipment changes without prior notification. This machine meets or exceeds applicable ANSI and CSA requirements based on machine configuration as originally manufactured for intended applications. Please reference the serial number plate on the machine for additional information.

Part No.: 3131024
R1219_A92.20
Printed in USA

JLG Industries, Inc.
1 JLG Drive
McConnellsburg, PA 17233-9533
Telephone 717-485-5161
Toll-free in US 877-JLG-LIFT
Fax 717-485-6417
www.jlg.com

An Oshkosh Corporation Company